

Bosch Motorsport 201 In-line Fuel Pump

>200l/h @5bar



Brand: Bosch Motorsport
Product Code: BOS0580464201
Availability: 7 Days
Weight: 0.50kg
Dimensions: 15.00cm x 5.00cm x 5.00cm

Price: \$327.31

Short Description

Newer version of the venerable "979" fuel pump with higher pressures for less amps.

Description

Smaller and lighter, the newer version can also sustain higher pressures for less current draw. As used in V8 Supercar.

- >200l/h @ 5bar
- Supercedes the 0 580 254 979
- M14x1.5 inlet fitting
- M12x1.5 outlet fitting
- M4 and M5 +/- screw terminals
- No non-return check valve
- Incl. Pressure relief valve
- 60mm diameter body

Specifications



BOSCH

>200l/h @5bar In-line Fuel Pump

0 580 464 201



- Supercedes the 0 580 254 979
- Flows >200l/h @ 5bar
- M14x1.5 inlet fitting
- M12x1.5 outlet fitting
- M4 and M5 +/- screw terminals
- No non-return check valve
- Includes pressure relief valve
- 60mm diameter body
- Not suitable for voltage regulation
- Compatible with Gasoline and Diesel

Pinout

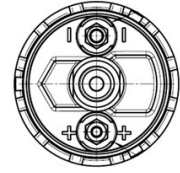

Dimensions

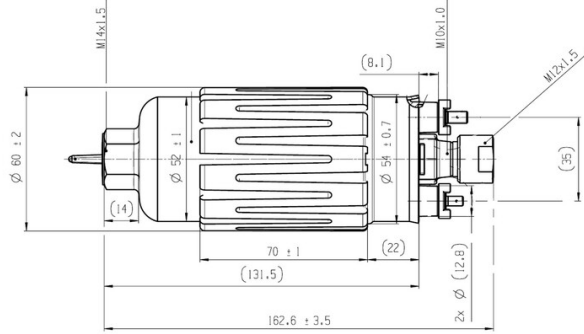

Characteristic Data

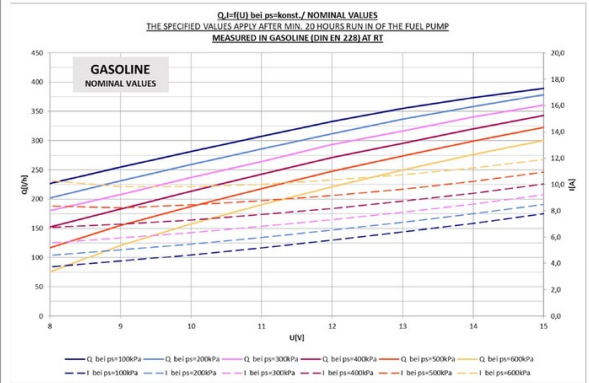

Installation Notes

Operating Voltage: 6 to 15V | Mount with rubber isolation for maximum life
Hydraulic connectors not attached to pump, included in the packaging