

Bosch Motorsport FP130 EFI Fuel Pump

Brand: Bosch Motorsport
Product Code: BOS0580464070
Availability: In Stock
Weight: 1.00kg
Dimensions: 20.00cm x 6.00cm x 6.00cm

Price: \$175.00

Short Description

Genuine Bosch Motorsport FP130 fuel pumps. Can pump up to 130lph at 3 bar. Ideal for classic EFI conversions.

Description

Quiet, efficient operation from a roller cell pump, the FP130 is ideal for classic EFI conversions up to 350HP.

Biofuel can be delivered up to E85 although this does shorten lifetime.

Also used in many early Dallara F3 applications.

>130l/h @3bar In-line Fuel Pump

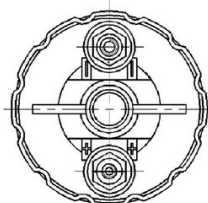
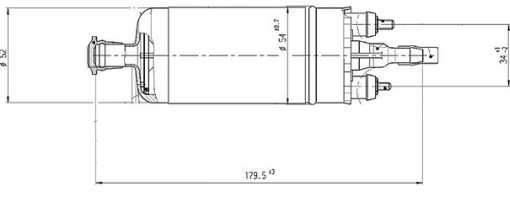
 <ul style="list-style-type: none">• >130l/h @ 3bar• 12mm inlet fitting• 8mm outlet fitting• M4 and M5 +/- screw terminals• Draws ~7A @ 3bar• 52mm diameter body	<p><u>Electrical Connection</u></p> 
<p><u>Dimensions</u></p> 	<p><u>Characteristic Data</u></p> <p>See description. For further details contact Bosch Motorsport</p>
<p><u>Notes</u></p>	

Robert Bosch (Australia) Pty Ltd | www.bosch-motorsport-shop.com.au | motor.sport@au.bosch.com | www.facebook.com/BoschMotorsportAustralia

Technical Characteristics

Application

Fuel pressure up to 5 bar

Delivery rate at 3 bar and 22°C 130 ± 5 l/h at 14 V

Pressure limiting valve 8 bar rel.

Fuel compatibility E85

Operating temperature range -20 to 90°C

Storage temperature range -40 to 70°C

Max. vibration 3 mm at 10 to 18 Hz ?40 m/s² at 18 to 60 Hz

Mechanical Data

Diameter 60 mm

Length 155 mm

Weight 670 g

Mounting Clamping

Electrical Data

Supply voltage 6 to 16.5 V

Operating voltage 13.8 V

Load current at 3 bar and 22°C 7A ± 1 A

Characteristic

Surface coating None

Color Silver

Non-return valve External

Fuel filtering External, on pressure side

Connectors and Wires

Electrical connector +M4/-M5

Electrical matting connector With ring wire M4 and M5

Mechanical connector intake side 12mm hose barb

Mechanical connector pressure side 8mm hose barb

Product Gallery

