

## Electronic throttle actuator



**Brand:** Jenvey  
**Product Code:** ETA2  
**Weight:** 0.25kg  
**Dimensions:** 20.00cm x 10.00cm x 10.00cm

**Price: \$1,190.00**

### Short Description

The Jenvey ETA2 Motorsport electronic throttle actuator has been created specifically for use with motorsport and high-performance engines. It will operate Jenvey individual throttle systems as well as other applications requiring fast and accurate response within its operating range.

### Description

The Jenvey ETA2 Motorsport electronic throttle actuator has been created specifically for use with motorsport and high-performance engines. It will operate Jenvey individual throttle systems as well as other applications requiring fast and accurate response within its operating range. All major components, with the exception of the high-performance DC motor, have been designed, developed and manufactured at the Jenvey Dynamics headquarters in the UK. Prototype tests have exceeded 1,000,000 cycles of normal operation without failure. The throttle actuator ETA2 consists of a DC Motor with reduction gearing and is available with a large range of actuating levers and return springs. It can be driven in either direction and includes adjustable end stops. An adjustable limp home spring module is available. Jenvey can supply a range of mounting brackets to fit to the majority of the Jenvey throttle body range. Advantages of electronic actuation include: packaging, autoblip for paddle shift, launch control, anti-lag, switchable pedal map, controllable push to pass strategy, pit lane speed control, traction control, variable bank to bank control, warm-up (increased airflow), soft engine safe mode, and the ability to combine with torque based strategies allowing ancillary load

compensation and hybrid integration. In all applications it is necessary to seek advice from the ECU supplier regarding the essential tuning of the actuator control system (normally a PID or PI control) and the associated safety systems. Ultimately electronic throttle applications are safer than mechanical cable application due to evaluation of the pedal position against throttle position and the ability to power the throttles closed. We recommend that set-up and tuning is only undertaken in conjunction with ECU suppliers and/or their recommended agents.

### **Mechanical variations:**

- The unit is provided with parts for standard configurations for single body (SF) 4 body kits and twin TB/TH/TF/TA kits.
- Mounting are also available for Ford Cyclone V6 TiVCT variants.
- Operating lever type and location (LH or RH) – default is multi-position lever (ORU1+extender).
- Return spring – none, LH or RH, soft, medium or strong – default is with no return spring.
- Actuator position feedback sensor – left or right (using Jenvey throttle position sensors, TP1, TP11 or TP8) – NOT INCLUDED.

### **Specifications**

#### **Actuator specifications:**

- Temp range of operation: -20 to 140 degC
- Voltage range: 10V to 16V
- Gear ratio: 20:1
- Max torque: 3600Nmm
- Max current: 8 amps
- Electrical connector: 2 pin AMP Superseal connector male pin
- Loom connector required: 2 pin AMP Superseal connector female pin
- Throttle position sensor: TP1, TP8 or any to fit an 8mm shaft with a 6mm flat
- Electrical connector (throttle position): TP1 and TP8 supplied with AMP Econoseal connector
- WIRING – Power on PIN 1 rotates the actuator anti-clockwise when looking at the side of the actuators with Jenvey logo and serial number.
- Mount orientation: Any
- Rotation: Maximum 100 degrees, clockwise or anti-clockwise.
- Limp home: adjustable to suit application in clockwise or anti-clockwise actuation
- Expected time: 0 to 100% (stable) < 0.08s as tested on 4 single SF bodies (soft springs)

- Unit weight: 500 grams ? Base unit cost: £495.00
- Max continuous (holding) current: < 2A
- Power off return time: Dependant on spring and throttle body specification – max 1 second

- **Motor specifications:**

- Max torque (motor): 180Nmm
- Motor No load speed (rpm): 5200
- Motor inertia: 42 gcm<sup>2</sup>

### **Set up and calibration info**

**IMPORTANT:** Damage will occur if the unit is driven dynamically into the mechanical stops or is used before the correct tuning is undertaken. Please remember that the throttle is working as soon as the ignition is switched on. If the system has not been calibrated before the ignition is switch on this is likely to lead to immediate failure. The ETA2 unit should not be stopped with internal end stops unless using the limp home module for the closed throttle stop. The full throttle stop should be on the throttle bodies and the closed throttle stop either on the butterflies or preferably on the idle adjuster, adjusted so the butterflies are just off closed throttle. The ECU should then be calibrated to ensure the systems does not drive dynamically into these stops. It should be noted that the Jenvey ETA2 is an actuator only and contains no electronics to link pedal position to throttle position. This information must be provided to the actuator by the ECU or motor controller using a minimum of 2 throttle position signals to feedback position. It is also necessary to ensure a minimum of 2 independent position sensors (dual redundant) are run on the pedal. It is preferable to use the return springs on the throttle bodies rather than in the actuator. This helps to eliminate mechanical backlash, improve control and ensure the throttles close on power down or linkage failure.

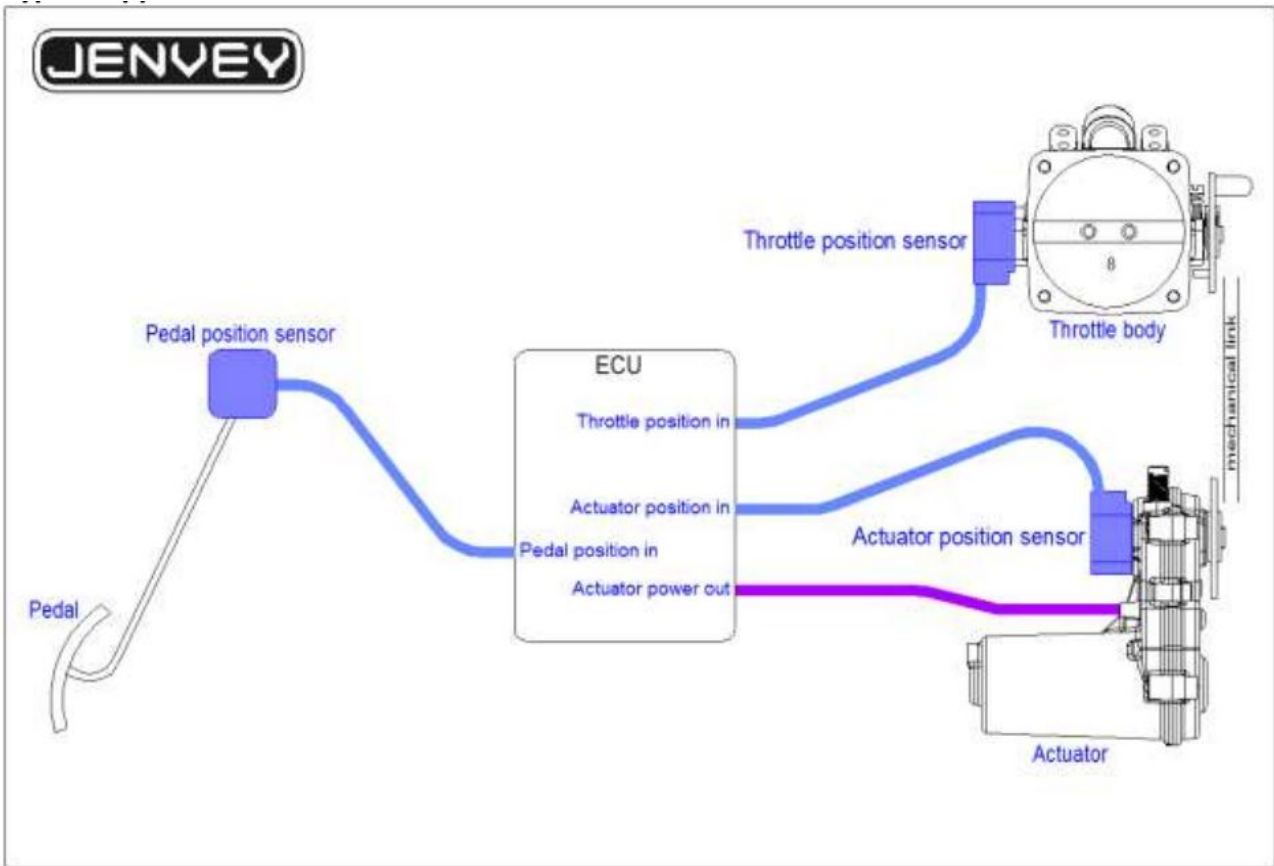

**Installation**

**Single body set-up: ETA2-SF**



## Twin body set-up: ETA2-TBP

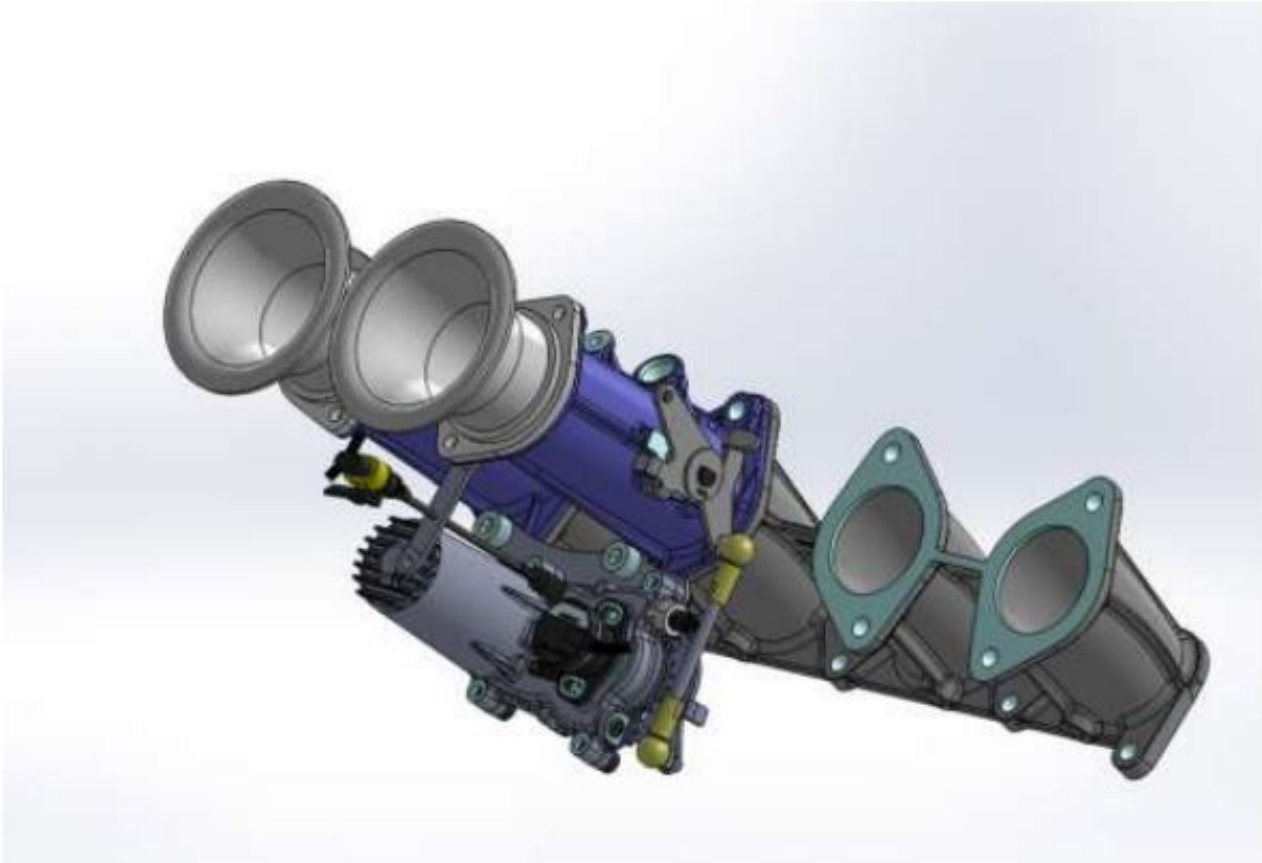

## Product Gallery

