

Bosch Motorsport In-line Fuel Pump >200l/h @5bar 202



Brand: Bosch Motorsport
Product Code: BOS0580464202
Availability: 7 Days
Weight: 0.50kg
Dimensions: 15.00cm x 5.00cm x 5.00cm

Price: \$264.00

Short Description

Newer version of the "984" fuel pump with higher pressures for less amps.

Description

Supercedes the older 0580254984 with slimmer body and more efficient pump.

This pump is capable of higher pressure with less current draw than the old version due to an improved impeller and motor design.

- >200l/h @ 5bar
- Supercedes the 0 580 254 984
- 12mm inlet fitting
- M12x1.5 outlet fitting
- M4 and M5 +/- screw terminals
- Length of pump 12mm longer than predecessor due to screw in hydraulic connection
- No non-return check valve
- 60mm diameter body
- Compatible with Gasoline and Diesel

Specifications



>275l/h @5bar In-line Fuel Pump

0 580 464 200



- Supercedes the 0 580 254 044
- Flows ~10% higher than 044 at 7bar
- Weighs 15% less than 044 at 860g
- Current draw similar to 044
- M18x1.5 inlet fitting
- M12x1.5 outlet fitting
- External non return valve
- Pressure relief valve 8-10bar
- Not suitable for voltage regulation
- Compatible with Gasoline and Diesel

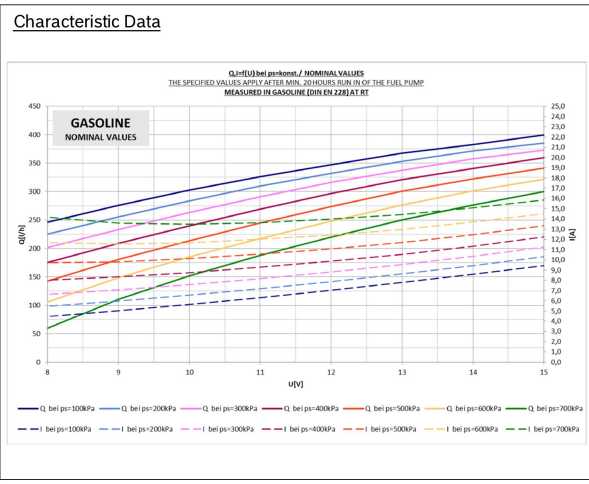
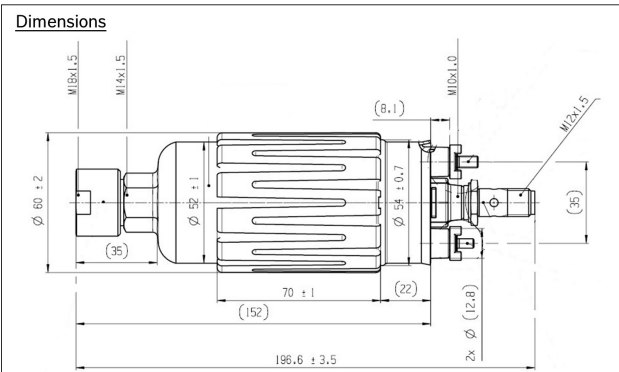
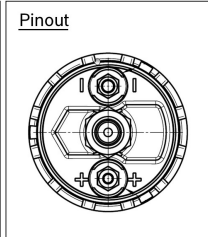

Installation Notes

Operating Voltage: 6 to 15V | Mount with rubber isolation for maximum life
Hydraulic connectors not attached to pump, included in the packaging