

# Bosch Motorsport In-line Fuel Pump >275l/h @5bar



**Brand:** Bosch Motorsport  
**Product Code:** BOS0580464200  
**Availability:** 7 Days  
**Weight:** 0.50kg  
**Dimensions:** 15.00cm x 5.00cm x 5.00cm

**Price: \$295.00**

## Short Description

Newer version of the venerable "044" fuel pump with higher pressures for less amps.

## Description

The "044" fuel pump was replaced in 2021 with a newer, improved version. This pump is capable of higher pressure with less current draw than the old version due to an improved impeller and motor design.

- >275l/h @ 5bar
- Supercedes the 0 580 254 044
- Flows ~10% higher than 044 at 7bar
- Weighs 15% less than 044 at 860g
- Current draw similar to 044
- M18x1.5 inlet fitting and M12x1.5 outlet fitting
- External non return valve
- Pressure relief valve 8-10bar
- Not suitable for voltage regulation
- Compatible with Gasoline and Diesel

# Specifications



## >275l/h @5bar In-line Fuel Pump

0 580 464 200



- Supercedes the 0 580 254 044
- Flows ~10% higher than 044 at 7bar
- Weighs 15% less than 044 at 860g
- Current draw similar to 044
- M18x1.5 inlet fitting
- M12x1.5 outlet fitting
- External non return valve
- Pressure relief valve 8-10bar
- Not suitable for voltage regulation
- Compatible with Gasoline and Diesel

### Pinout

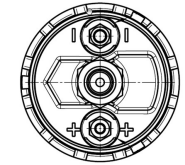

### Dimensions

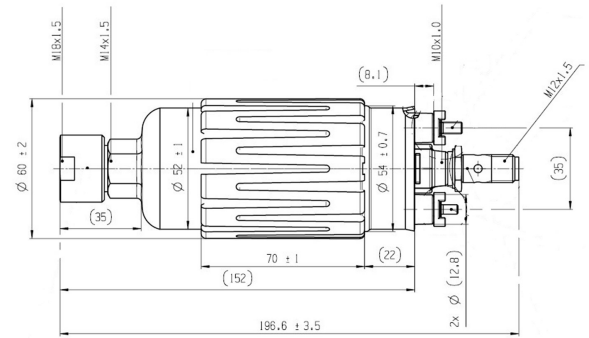

### Installation Notes

Operating Voltage: 6 to 15V | Mount with rubber isolation for maximum life  
Hydraulic connectors not attached to pump, included in the packaging

### Characteristic Data

