

Bosch Motorsport DBW Accelerator Pedal Assembly

Brand: Bosch Motorsport
Product Code: BOS0280755051
Availability: 7 Days
Weight: 0.50kg
Dimensions: 15.00cm x 10.00cm x 5.00cm



Price: \$127.50

Short Description

- Generic use
- Custom applications
- For use with ECU's controlling Electronic throttle systems

Description

- 16degree (~70mm) travel
- Firewall mounted hanging design
- Redundant dual output potentiometers suitable for use with Electronic throttle bodies
- Use 6-pin Compact mating connector F 005 X11 508

Specifications



Accelerator Pedal Sensor



- 16degree (~70mm) travel
- Firewall mounted hanging design
- Redundant dual output potentiometers suitable for use with Electronic throttle bodies

Pinout

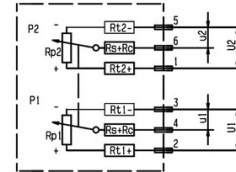
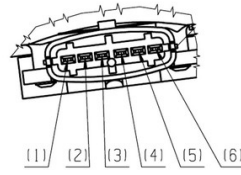

$$Rn1 = (Rt1-) + Rp1 + (Rt1+)$$

$$Rn2 = (Rt2-) + Rp2 + (Rt2+)$$

Dimensions

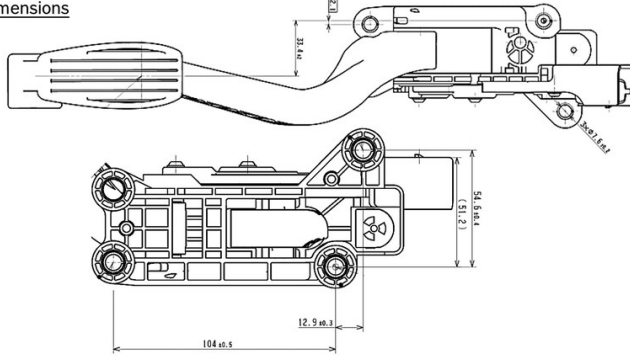

Characteristic Data

70±3	0.89 ± 0.04	see Potentiometr Synchronisation
66	0.86 ± 0.04	
0	0.15 ± 0.02	
Pedal Way [mm]	u1/U1	u2/U2
Linearity	± 0.02 u/U	
Synchronisation P1/P2	$\left \frac{u1}{U1} - \frac{u2}{U2} \right \leq 0.014 \frac{u}{U}$	

Installation Notes

Mating Connector : F 005 X11 508

Max. installation torque : 9 ± 1.5 Nm | Operating voltage = 5 ± 0.3 V | Operating temperature = -40 - 80°C